



# Données techniques / Série H-15000

## Technical data / Series H-15000



Série Series	Interchangeabilité Interchangeability	Taille Size		DN Nominal diam. (mm)	Adaptation Connection	Pression de service maxi <sup>(2)</sup> Maximum working pressure <sup>(2)</sup>		Débit repère ( $\Delta p$ 1 bar) Reference flow ( $\Delta p$ 1 bar) (l/mn)
		ISO <sup>(1)</sup> (mm)	pouce inch			bar	psi	
<b>H-15000</b>	Norme ISO 7241-1 A ISO 7241-1 A Standard	6,3	1/4"	5,3	1/4	315	4565	10
		10	3/8"	7,3	3/8	315	4565	20
		12,5	1/2"	10,2	1/2	250	3625	40
		20	3/4"	13	3/4	250	3625	75
		25	1"	16,9	1	200	2900	140

### PLAGES DE PRESSION

Les champs d'application étant nombreux et variables, les pressions de service que nous indiquons constituent une aide dans le choix de votre coupleur mais en aucun cas une garantie de performance.

Des pics de pression ou des débits instantanés peuvent provoquer des dysfonctionnements mécaniques ou techniques.

### PRESSURE RATINGS

Since application conditions vary so widely, the pressures listed are intended as a guide only and not a guarantee of performance. Pressure peaks and extreme surge flows may cause a coupling to become inoperative.

# Série 15000H

Series



Taille Size		Type de raccordement End connection		Matière Material	Obturation Valve configuration	Joints Seals		Température d'utilisation Temperature range (°C / °F)
ISO <sup>(1)</sup> (mm)	pouce inch	G (BSPP)	NPT			Nitrile	Viton	
6,3	1/4"	X	X	Acier zingué bichromaté		S	▲	Nitrile (NBR) : -20°C +100°C -4°F +212°F
10	3/8"	X	X			S	▲	
12,5	1/2"	X	X			Zinc-plated steel, bichromate		S
20	3/4"	X	X	S				
25	1"	X	X	S				

- (1) La taille ISO correspond au diamètre intérieur du flexible ou au diamètre extérieur du tube rigide (définition suivant norme ISO 4397)  
The ISO size corresponds to the internal diameter of the hose or to the external diameter of rigid tube (as defined in ISO 4397 Standard)
- (2) Les valeurs indiquées sont des valeurs maximum, en position connectée. Pour le détail des pressions de service, veuillez vous référer aux pages de chaque série / The figures given are maximum values applying to a connected coupling. For detailed working pressure information please refer to individual series pages

Coupleurs double obturation / Double shut-off couplings

**S** Standard / Standard

**▲** Disponible hors catalogue / Available to special order



Série  
Series

# H-15000

## Caractéristiques techniques

- Coupleurs à double obturation
- Accouplement semi-automatique
- Verrouillage à billes
- Série conforme aux exigences de la norme ISO 7241-1 A
- Taille 1/2" disponible en version push-pull (douille à double action fixée en traversée de cloison - voir page 24)
- Bouchons de protection

## Technical data

- Double shut-off couplings
- Pull-to-connect couplings
- Ball-locking
- Meets the requirements of ISO 7241-1 Series A
- 1/2" size available in a push-pull version (double-acting sleeve, bulkhead-mounted - see page 24)
- Dust caps and plugs

## Directive européenne

Les DN de notre série H-15000 sont inférieurs à 25 mm.  
Ils sont conçus et fabriqués en application de l'article 3.3 de la Directive Européenne des Equipements sous Pression 97/23 CE.

## European directive

Our series H-15000 couplings have nominal diameters no greater than 25 mm.  
They are designed and manufactured under Article 3.3 of the European Pressure Equipment Directive 97/23 EC.



## Applications

Circuits et équipements hydrauliques

Agriculture  
Travaux publics

Fluides hydrauliques

## Applications

Hydraulic circuits and equipment

Agriculture  
Public works

Hydraulic fluids

## Nomenclature

- 1 Corps femelle / Socket body
- 2 Ailette / Valve guide
- 3 Ressort clapet / Valve spring
- 4 Clapet / Valve
- 5 Joint torique / O-ring
- 6 Bille / Ball
- 7 Corps mâle / Plug body
- 8 Joint de clapet / Valve seal
- 9 Douille / Sleeve
- 10 Bague anti-extrusion / Back-up ring

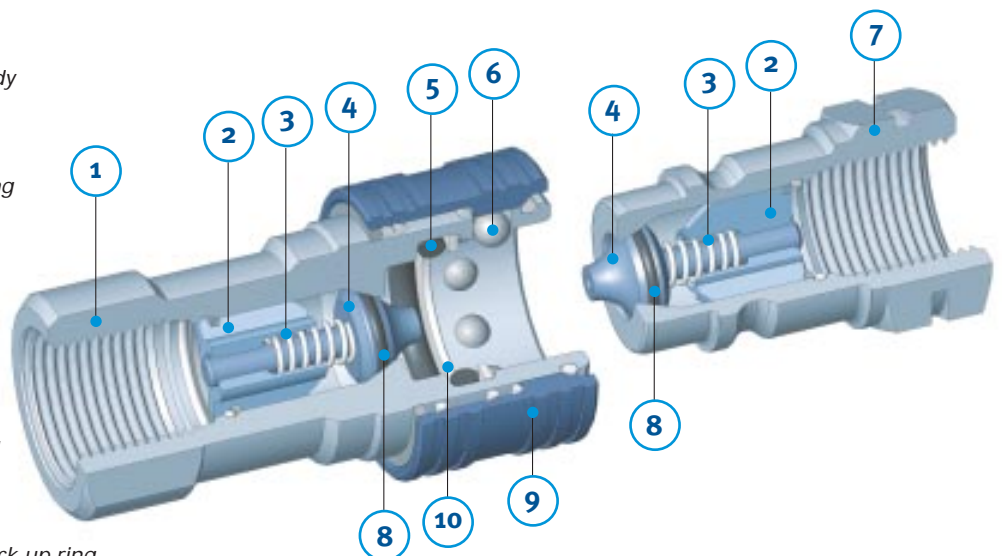

## Nomenclature

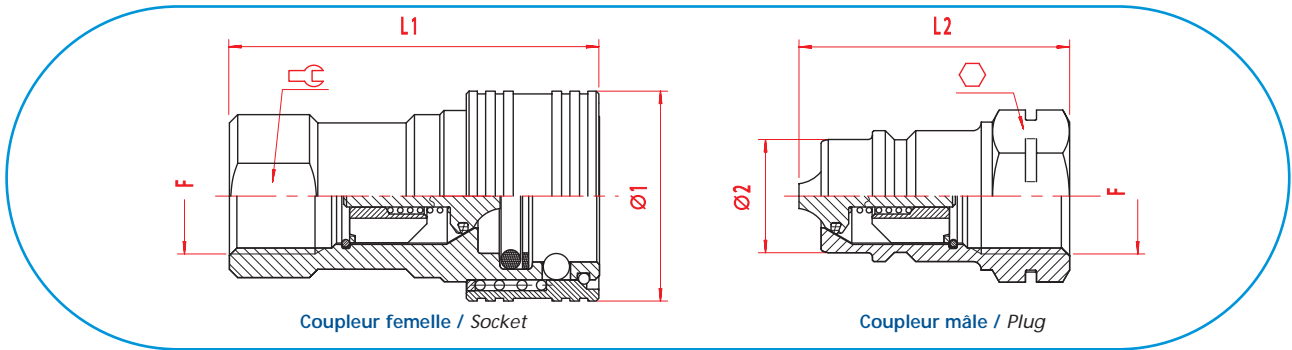

## ● Dimensions (mm) / Poids (g)

## Dimensions (mm) / Weights (g)

taille / size		DN / ND (mm)	adaptation (F) connection (F)	coupleur femelle / socket				coupleur mâle / plug				longueur / length connecté (ed)
ISO (mm)	pouce / inch			L1	ø1			L2	ø2			
6,3	1/4"	5,3	1/4 (G & NPT)	48	25	19	94	36	11,8	19	36	68
10	3/8"	7,3	3/8 (G & NPT)	56	30	23	139	41,5	17,3	23	62	76
12,5	1/2"	10,2	1/2 (G & NPT)	67	38	27	238	49	20,5	27	88	91
20	3/4"	13	3/4 (G & NPT)	83	48	35	484	61,5	29,1	35	194	110
25	1"	16,9	1 (G & NPT)	98	53	41	670	71,5	34,3	41	306	128

## ● Perte de fluide

## Spillage

taille ISO ISO size (mm)	DN / ND (mm)	perte de fluide à la déconnexion spillage per disconnection
6,3	5,3	0,35 ml
10	7,3	1,5 ml
12,5	10,2	2,6 ml
20	13	8,5 ml
25	16,9	13 ml

DN : Diamètre nominal / ND : Nominal diameter  
G = BSPP (BSP parallel male or female thread)



## Débit / Perte de charge Flow rate / Pressure drop

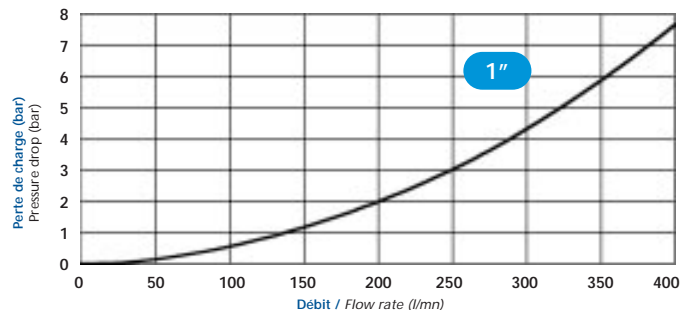
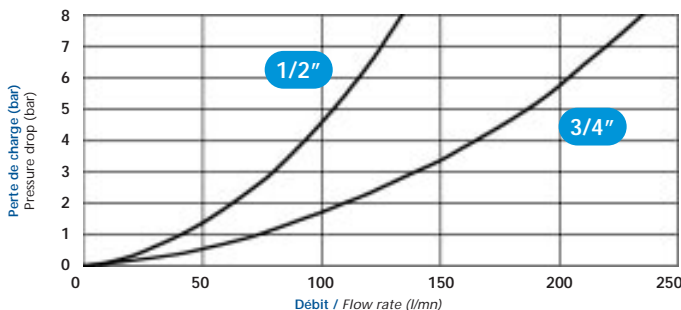
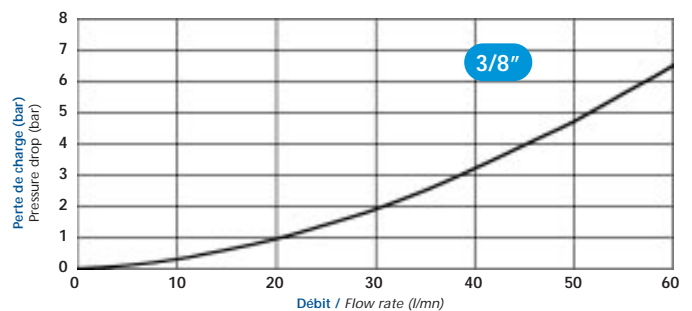
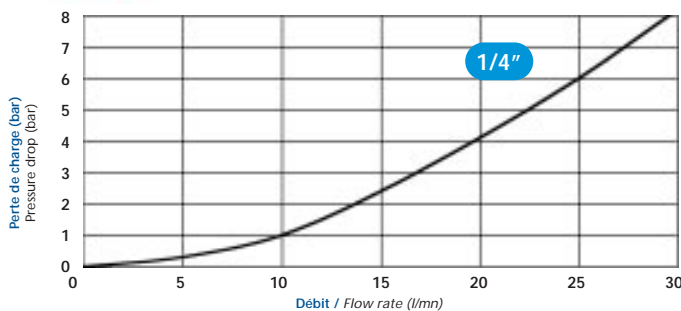

Huile hydraulique de viscosité 30 cSt à 40°C (104°F) / Oil viscosity 30 cSt at 40°C (104°F)



# Coupleurs hydrauliques / Verrouillage à billes

## Hydraulic couplings / Ball-locking



Norme ISO 7241-1 A  
ISO 7241-1 A Standard



5,3 ▶ 16,9 mm



10 ▶ 140 l/mn  
( $\Delta p$  1 bar)



200 ▶ 315 bar  
2900 ▶ 4570 psi



TEMPERATURE  
-20°C +100°C  
-4°F +212°F

### ● Références

### Part numbers

taille / size		DN / ND (mm)	adaptation (F) connection (F)	coupleur femelle / socket	coupleur mâle / plug
ISO (mm)	pouce / inch				
6,3	1/4"	5,3	G 1/4 1/4 NPT	HA 15011 00 HA 15211 00	HA 15012 00 HA 15212 00
10	3/8"	7,3	G 3/8 3/8 NPT	HA 15021 00 HA 15221 00	HA 15022 00 HA 15222 00
12,5	1/2"	10,2	G 1/2 G 1/2 push-pull* 1/2 NPT	HA 15031 00 HA 15036 00 HA 15231 00	HA 15032 00 HA 15032 00 ou/ou HA 15232 00 HA 15232 00
20	3/4"	13	G 3/4 3/4 NPT	HA 15041 00 HA 15241 00	HA 15042 00 HA 15242 00
25	1"	16,9	G 1 1 NPT	HA 15051 00 HA 15251 00	HA 15052 00 HA 15252 00

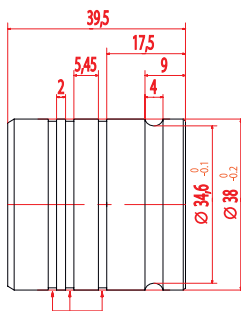

Gorges pour circlips ext.  $\varnothing$  38  
DIN 471 & AFNOR NF E 22-163  
Grooves for 38 mm dia. external  
circlips to DIN 471 & AFNOR NF E 22-163

#### \* Douille PUSH-PULL

Cette configuration permet d'obtenir une connexion et une déconnexion automatiques simplement par poussée et retrait du coupleur mâle. En cas de traction accidentelle sur le flexible, la douille à double action, fixée en traversée de cloison, permet le désaccouplement instantané des deux demi-coupleurs.

#### \* PUSH-PULL SLEEVE

This configuration provides automatic connection or disconnection via a simple push or pull of the plug. In the event of an accidental pull on the hose, the bulkhead-mounted double-action sleeve gives immediate, automatic disconnection.

### ● Bouchons de protection

### ● Dust caps and plugs

taille ISO ISO size (mm)	bouchon coupleur femelle dust plug	bouchon coupleur mâle dust cap
6,3	HP 15111 00	HP 15112 00
10	HP 15121 00	HP 15122 00
12,5	HP 15131 00	HP 15132 00
20	HP 15141 00	HP 15142 00
25	HP 15151 00	HP 15152 00



# Série 15000

# H



## Matériaux Materials

- Corps : Acier zingué bichromaté
- Douille : Acier zingué bichromaté
- Clapets : Acier zingué bichromaté
- Ressorts : Acier ou inox
- Billes : Inox
- Joints : Nitrile  
(Viton sur demande)

- Body: Zinc-plated steel, bichromate
- Sleeve: Zinc-plated steel, bichromate
- Valves: Zinc-plated steel, bichromate
- Springs: Steel or stainless steel
- Balls: Stainless steel
- Seals: Nitrile  
(Viton upon request)

## Bouchons de protection Dust caps and plugs

- PVC

- PVC



## Pressions de service maxi Max working pressures

taille ISO ISO size (mm)	DN / ND (mm)	pression de service / working pressure	
		connecté ou déconnecté / connected or disconnected	
6,3	5,3		315 bar / 4565 psi
10	7,3		315 bar / 4565 psi
12,5	10,2		250 bar / 3625 psi
20	13		250 bar / 3625 psi
25	16,9		200 bar / 2900 psi

Pour des pressions pulsées en position déconnectée, veuillez appliquer un coefficient de x0,5  
For pulsating pressures when disconnected apply a multiplier of 0.5